



LTMS

Liquid Transmission Measurement System

Installation and Operation Manual



Locations

Americas

Ocean Insight, Inc.

8060 Bryan Dairy Rd., Largo, FL 33777, USA

Manufacturing & Logistics

4301 Metric Dr., Winter Park, FL 32792, USA

Sales: info@oceaninsight.com

Orders: orders@oceaninsight.com

Support: techsupport@oceaninsight.com

Phone: +1 727.733.2447

Fax: +1 727.733.3962

Europe, Middle East & Africa

Sales & Support

Geograaf 24, 6921 EW Duiven, The Netherlands

Manufacturing & Logistics

Maybaachstrasse 11, 73760 Ostfildern, Germany

Email: info@oceaninsight.eu

Netherlands: +31 26-319-0500

Netherlands Fax: +31 26-319-0505

Germany: +49 711-341696-0

UK: +44 1865-819922

France: +33 442-386-588

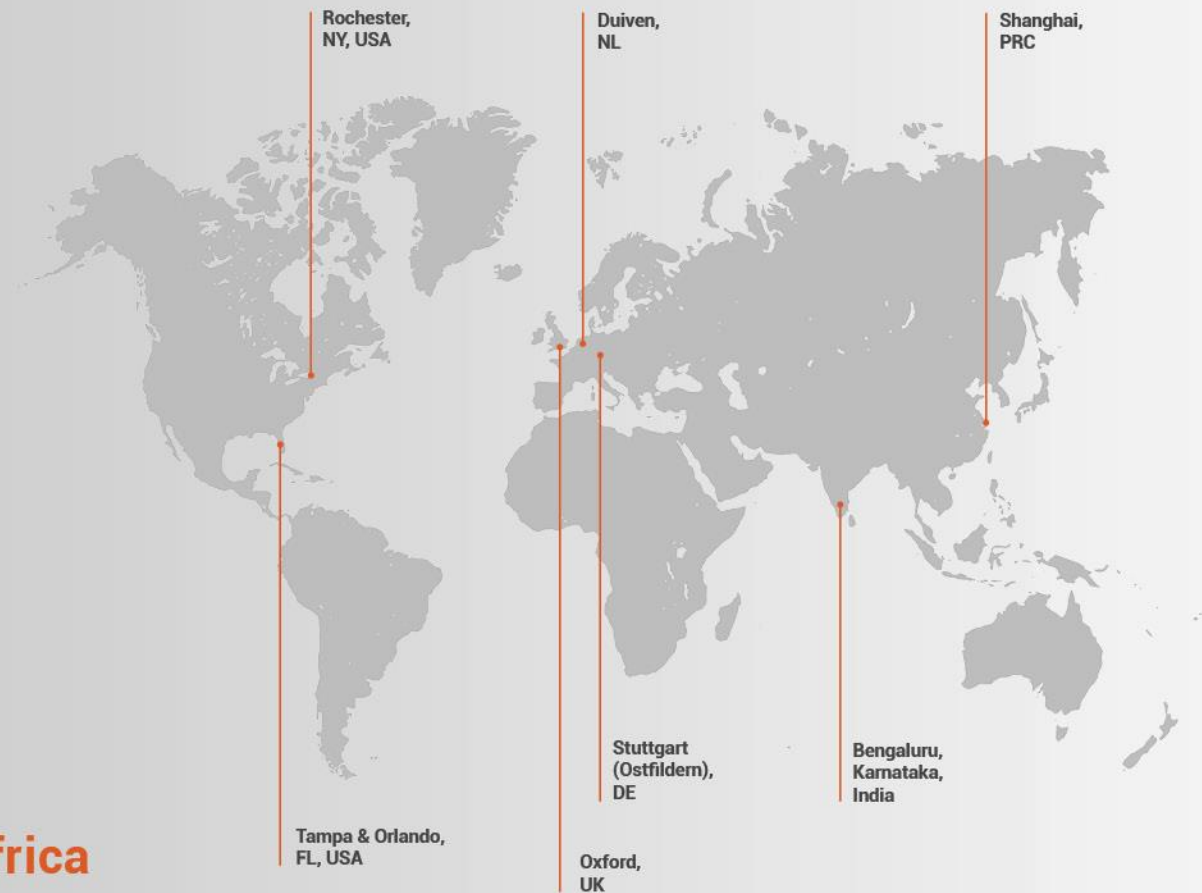

Asia

Ocean Insight China

666 Gubei Rd., Kirin Tower Suite 601B
Changning District, Shanghai, PRC, 200336

Email: asiasales@oceaninsight.com

China: +86 21-6295-6600

China Fax: +86 21-6295-6708

Japan & Korea: +82 10-8514-3797

Ocean Insight India

Prestige Shantiniketan, Gate no.2
Tower C, 7th Floor
Whitefield main road, Mahadevpura
Bengaluru-560048 Karnataka, India

Phone: +91 80-67475336

www.oceaninsight.com

Table of Contents

Before You Get Started	iv	Tubing Replacement	10
Warnings & Cautions.....	iv	Remove Tubing.....	11
Warranty.....	v	Disassembling the Old Pump Tubing	13
Certifications and Compliance.....	v	Assembling the New Pump Tubing.....	14
Introduction.....	1	Installing New Tubing	15
Product Description	1	Flow-cell Changeover Procedure.....	21
Operation	3	Troubleshooting	23
Installing the GUI	3	Specifications	25
Calibration.....	4		
Verify Calibration.....	6		
Make Sample Measurement	7		
Make Multiple Measurements.....	8		
Cleaning the Flow-Cell.....	9		

Copyright © 2020 Ocean Insight

All rights reserved. No part of this publication may be reproduced, stored in a retrieval system, or transmitted, by any means, electronic, mechanical, photocopying, recording, or otherwise, without written permission from Ocean Insight.

This manual is sold as part of an order and subject to the condition that it shall not, by way of trade or otherwise, be lent, re-sold, hired out or otherwise circulated without the prior consent of Ocean Insight, Inc. in any form of binding or cover other than that in which it is published.

Trademarks

All products and services herein are the trademarks, service marks, registered trademarks or registered service marks of their respective owners.

Limit of Liability

Every effort has been made to make this manual as complete and as accurate as possible, but no warranty or fitness is implied. The information provided is on an “as is” basis. Ocean Insight shall have neither liability nor responsibility to any person or entity with respect to any loss or damages arising from the information contained in this manual.

Before You Get Started

Warnings & Cautions

Cautions

Caution: Never let the flow-cell sit empty, always keep it full of clean water when not in use. This is to reduce deposits from building up on the flow-cell surface.

Caution: Never use with liquids warmer than 60°C.

Caution: Never operate the fluid handling system with the guards removed.

Caution: Never operate the fluid handling system with the hoses removed.

Caution: Do not immerse the device in any fluid, or place fluids on top. This may cause an electrical hazard. Do not use if accidental wetting occurs.

Caution: Do not gas sterilize or autoclave this device.

Caution: Consult local codes and ordinances for proper disposal of equipment and other consumable goods.

Warranty

For the most current warranty information, please visit OceanInsight.com.

Certifications and Compliance



WEEE Compliance

The WEEE symbol on the product indicates that the product must not be disposed of with normal household waste. Instead, such marked waste equipment must be disposed of by arranging to return to a designated collection point for the recycling of waste electrical and electronic equipment. Separating and recycling this waste equipment at the time of disposal will help to conserve natural resources and ensure that the equipment is recycled in a manner that protects human health and the environment

ISO Certification

Ocean Insight, the industry leader in miniature photonics, has been certified for ISO 9001:2015 certification applicable to the design and manufacture of electro-optical equipment.

Introduction

Product Description

The LTMS system is a spectroscopy-based product for real-time, in-line monitoring of liquids including industrial dyes and plating baths, ingredients in foods and beverages, chemical coatings for metals and other industrial liquid applications. The system comprises a rugged transmission/absorption platform with a compact, rugged benchtop configuration suitable for harsh environments. A built-in cuvette holder or flow-cell setup with automatic fluid handling are included.

The LTMS system will be custom configured for your facility and application. The instructions contained herein provide general guidance for the use and maintenance of the system. The uniqueness and high degree of customization may require different or additional steps that will be outlined during the installation and training received from Ocean Insight.

The LTMS software is designed for industrial settings and provides a simple client-server interface for operation over either ethernet or serial communications (RS-232/RS-485). This interface is straightforward, human-readable, and may be customized for specific applications. One or even multiple LTMS sensors can thus be controlled from a single automation platform, which can trigger measurements and in turn receive either analyte concentration estimates or full spectral transmission/absorbance measurements.

The LTMS system uses long-lifetime LEDs for illumination. These LEDs do not need bulb replacements.

An image of the fully assembled LTMS System can be found in Figure 1.

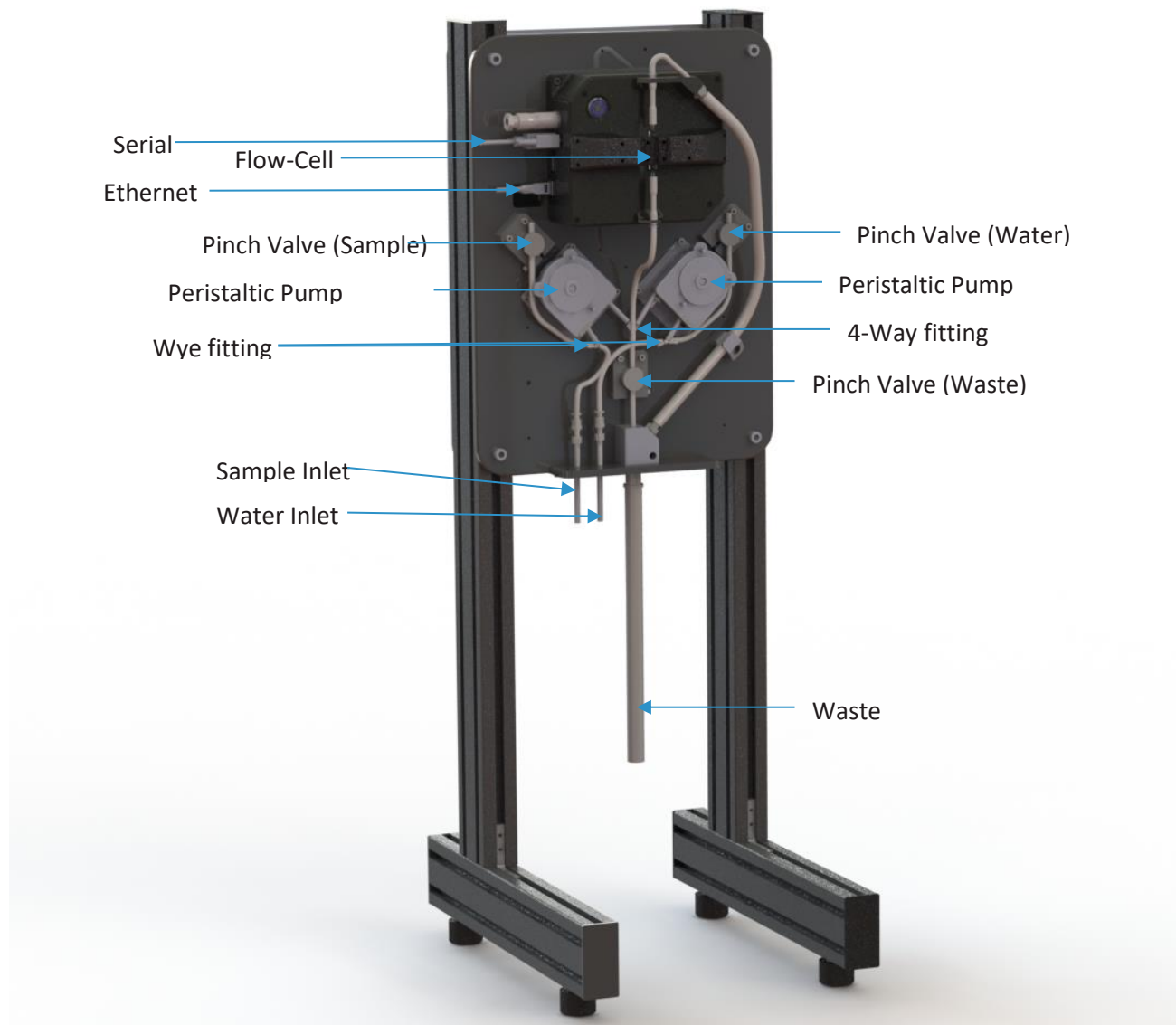

Figure 1 The fully assembled LTMS System with parts labeled.

Operation

This section will guide the user through the general operation of the LTMS. The system must be assembled, installed, powered up, and connected to the software prior to operation. Ensure the proper installation of fluid handling lines installed in the appropriate tanks: clean water and sample ensuring no leaks are visible. The workflow is as follows:

- Calibration
- Verification of the calibration
- Saving a master calibration
- Loading a concentration model
- Making a measurement

Installing the GUI

- Install MATLAB Runtime Engine on the user computer.
 - <https://www.mathworks.com/products/compiler/matlab-runtime.html>
 - 1.7 GB file size
 - Version R2018b (9.5)
- Install the Microsoft Visual C++ Redistributable on the user computer.
 - VC_redist.x64.exe
- Copy the FDLTMSG2_Main.exe file to the user computer.
- Connect the computer to the LTMS system via Ethernet cable.
- Set the IP address for the ethernet port
 - 10.14.15.1

Calibration

- Set the “Fluid Handling” toggle button to “On” if you want to use the fluid handling.
- Set the IP Address.
 - 10.14.15.x
 - X is the serial number
- Press “Connect to LTMS.”

The screenshot displays the software interface for the MNL-1017. It is divided into several sections:

- Manual Control:** Contains buttons for "Calibrate", "Save Out Cal", and "Measure". It also features toggle switches for "Conc. Mode" (set to Off) and "Save Data" (set to On), along with a "Delay (sec)" input field set to 0.
- Integration Times (Cal):** Shows "S0 Int" and "Ref Int" both set to 0 us.
- Integration Times (Measurement):** Shows "S0 Int" and "Ref Int" both set to 0 us.
- LTMS Connection:** The "IP Address" field is set to "10.14.15.4" and the "Connect to LTMS" button is highlighted with a red oval.
- Axis Adjustment:** Shows "X Min" set to 400, "X Max" set to 700, and "Y Min" set to 0.
- Fluid Handling:** The "Fluid Handling" toggle switch is set to "On" and is highlighted with a red oval. Other controls include "Toggle Water Pump", "Toggle Sample Valve", "Flush volume" (set to Low), and "Water to Sample".

In the background, a graph shows a flat line at 0.0 on the y-axis (ranging from 0 to 0.2) against a wavelength of 0 to 0.5 nm on the x-axis.

- When the system is connected, the “Connect to LTMS” button will be GREEN and the text will change to “Disconnect LTMS”.
- Let the system warm up for 45 minutes or more.
- Ensure the water inlet tube is installed in a vessel of clean water. The clean water should be as clean as possible, distilled or RO water is preferred.
- If using the system fluid handling, press the “Sample to Water” Button.
 - Repeat 3 times to ensure a clean flow-cell.
- If not using the system fluid handling, ensure there is clean water in the flow-cell or cuvette.
- Press “Calibrate”.

The screenshot displays the software interface with several sections:

- Manual Control:** Contains a red "Calibrate" button (circled in red), a red status indicator, and toggle switches for "Conc. Mode" and "Save Data". Below are "Save Out Cal" and "Measure" buttons, a "Delay (sec)" input field set to 0, and an "Auto Fluid Handling" checkbox with "Reps" set to 1.
- Integration Times (Cal):** Shows "S0 Int" and "Ref Int" both set to 0 us.
- Integration Times (Measurement):** Shows "S0 Int" and "Ref Int" both set to 0 us.
- LTMS Connection:** Shows "IP Address" as 10.14.15.3 and a green "Disconnect LTMS" button.
- Axis Adjustment:** A graph with "Wavelength (nm)" on the x-axis (400 to 700) and a y-axis (0 to 20). Below the graph are input fields for "X Min" (400), "X Max" (700), "Y Min" (0), and "Y Max" (105).
- Fluid Handling:** Includes a "Fluid Handling" toggle (Off), a "Flush Volume" toggle (Low), and several buttons: "Toggle Water Pump", "Toggle Water Valve", "Toggle Sample Pump", "Toggle Sample Valve", "Toggle Drain Valve", "Toggle Relay 6", "Water to Sample", "Sample to Water" (circled in red), and "Disable All".

Verify Calibration

- Press “Sample to Water”.
- Press “Measure”
- Verify that the temperature did not change more than 0.2°C.
 - Calibration and Current temps should be within 0.2°C for each spectrometer (S0 and Ref). See arrows.
- Make sure transmission measurement is between 99.5% and 100.5% at all wavelengths
- If not, recalibrate and repeat.

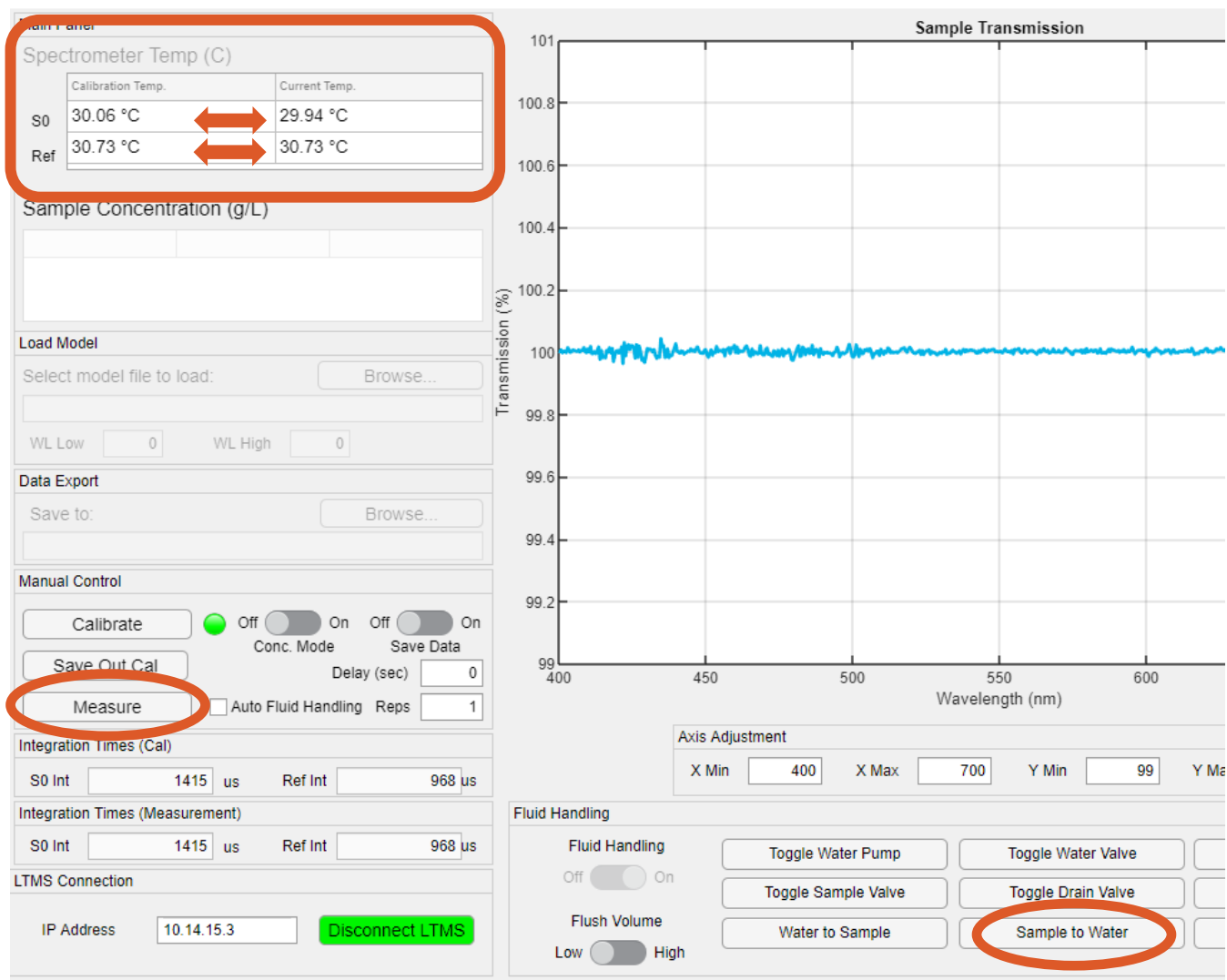

Make Sample Measurement

- Load Model
 - Enable Concentration Mode by toggling the switch above “Conc. Mode” as seen in the screenshot.
 - Load sample model file
- Setup Data Saving
 - Enable saving data
 - Select directory for data files
- Run “Water to Sample”.
- Measure

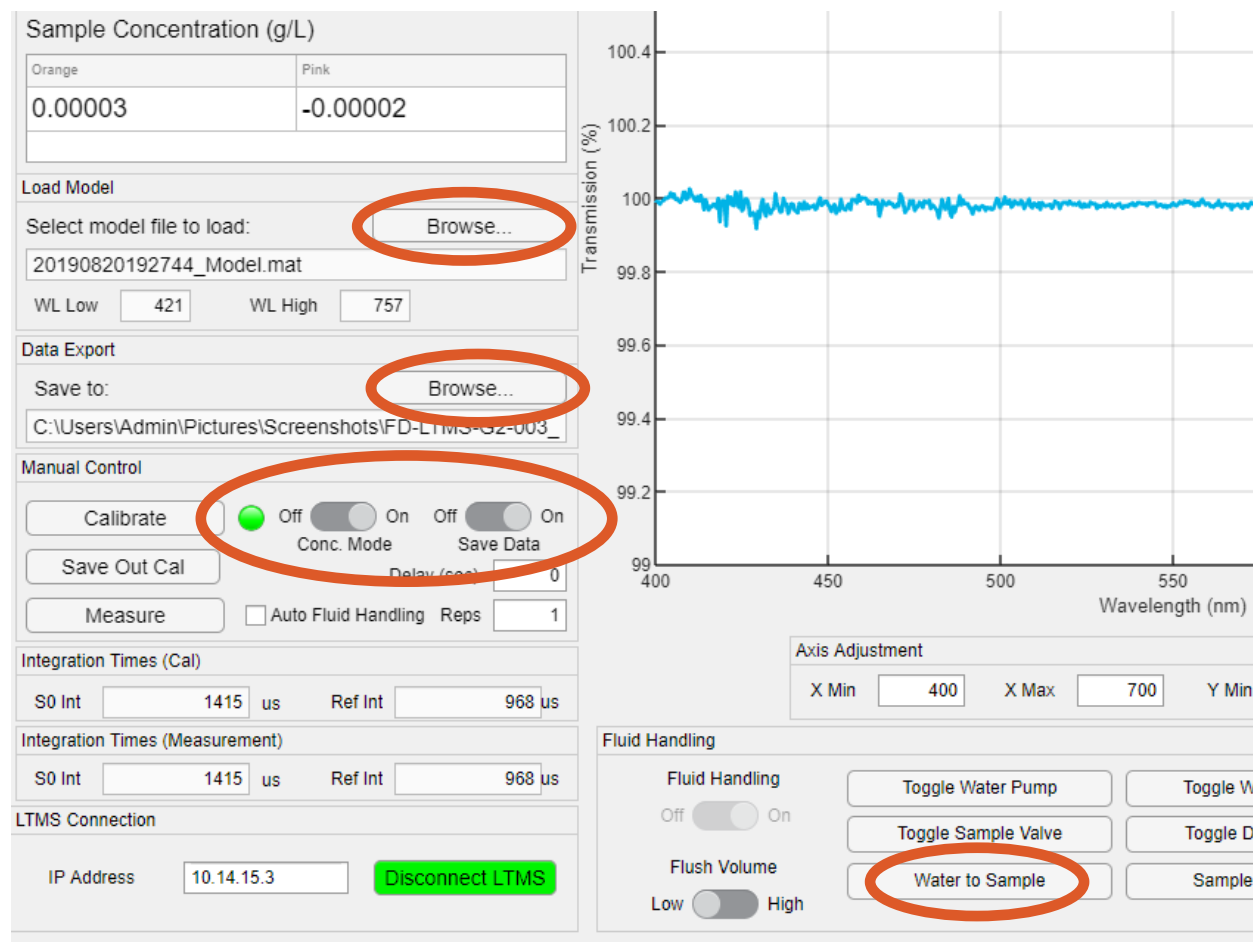

Make Multiple Measurements

- Enter the number of measurements you want to make in the “Reps” field.
- Enter the desired delay time, in seconds, between measurements.
- Check “Auto Fluid Handling” and the system will run the following sequence for each measurement.
 - “Sample to Water” then “Calibrate”.
 - “Water to Sample” then “Measure”.
- Press “Measure” to begin.

The screenshot displays the software interface for Ocean Insight. The 'Manual Control' section is highlighted with a red box and contains the following controls:

- Calibrate** button
- Save Out Cal** button
- Measure** button
- Conc. Mode** toggle switch (set to Off)
- Save Data** toggle switch (set to On)
- Delay (sec)** input field (set to 0)
- Auto Fluid Handling** checkbox (unchecked)
- Reps** input field (set to 1)

Other visible settings include:

- Load Model:** Select model file to load: 20190820192744_Model.mat; WL Low: 421; WL High: 757
- Data Export:** Save to: C:\Users\Admin\Pictures\Screenshots\FD-LTMS-G2-003_
- Integration Times (Measurement):** S0 Int: 1415 us; Ref Int: 968 us
- LTMS Connection:** IP Address: 10.14.15.3; Disconnect LTMS button
- Fluid Handling:** Fluid Handling toggle (Off), Flush Volume toggle (Low), and buttons for Toggle Water Pu, Toggle Sample V, and Water to Samp.

On the right, a graph shows **Transmissi** (Y-axis, 99 to 100) versus **X Min** (X-axis, 400 to 500). The graph displays a blue line representing the transmission signal, which is stable around 99.8-99.9.

Cleaning the Flow-Cell

A clean flow-cell is important for accurate measurements. Scale, debris, scratches, and other detritus can degrade the signal. If the flow-cell is chipped, scratched, or the transparency is otherwise compromised it will need to be replaced. To prevent unnecessary replacement, ensure your flow-cell is clean after use. After sampling, prior to filling with clean water, the flow-cell should be flushed clean with a solution appropriate for the sample being measured. See below for recommended cleaning solutions.

Solvent	Material	Suggested Cleaning Methods
<i>Aqueous</i>	Protein, DNA, Biologics	Warm water with detergent, Dilute acid rinse, Copious water rinse
<i>Aqueous</i>	Salt solution Warm water	Acid rinse, copious water rinse
<i>Aqueous</i>	Basic solutions	Warm water with detergent, Dilute acid rinse, Copious water rinse
<i>Organic</i>	Oil based	Rinse with solvent, Warm water with detergent, Dilute acid rinse, Copious water rinse
<i>Organic</i>	Alcohol solutions	Rinse with solvent, Copious water rinse
<i>Organic</i>	Acidic solutions	Rinse with solvent, Copious water rinse
<i>Organic</i>	Basic solutions	Rinse with solvent, Dilute acid rinse, Copious water rinse

The use of RO, or distilled water, is highly recommended to prevent scale. After cleaning, the flow-cell should not be allowed to dry out and should be stored filled with RO or distilled water.

Tubing Replacement

Over time, the tubing used in the LTMS may become damaged and need to be replaced. Here are the instructions for maintenance and tubing replacement.

- Required Tools
 - Scissors or sharp cutters (something to cleanly cut the tubing)
- Required supplies
 - Tubing
 - Rubber grommet (Can be reused)
 - Retention clip (Can be reused)



Tubing



Rubber Grommet



Retention Clip

Remove Tubing

Prior to removing, or servicing, the tubing ensure that the fluid handling system is not running. Power to the fluid handling system should be off or disconnected. All tubing in the LTMS system is replaceable. Prior to installing new tubing, remove all old tubing except the flow-cell and tubing directly coupled to the flow-cell.

LTMS System

With all tubing removed, except flow-cell and tubing directly attached to the flow-cell, the LTMS system looks as below.

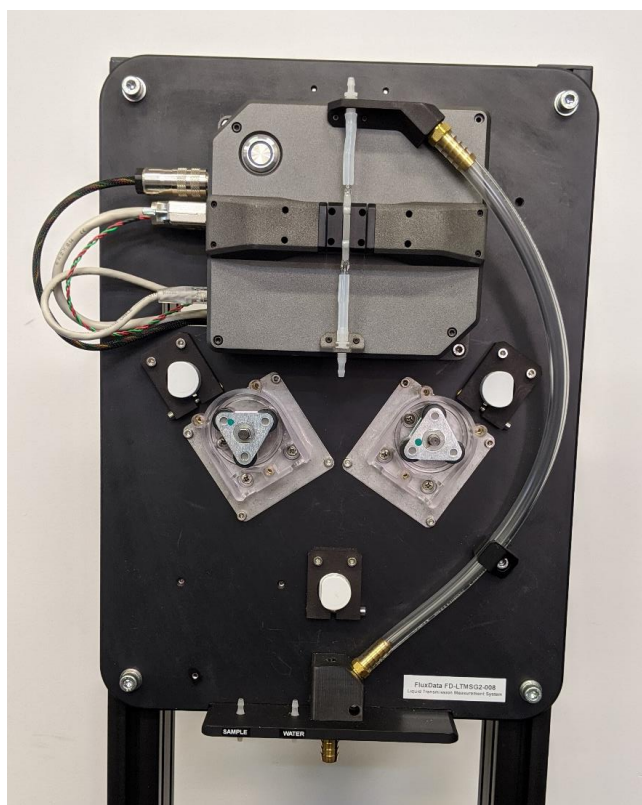

Peristaltic Pumps

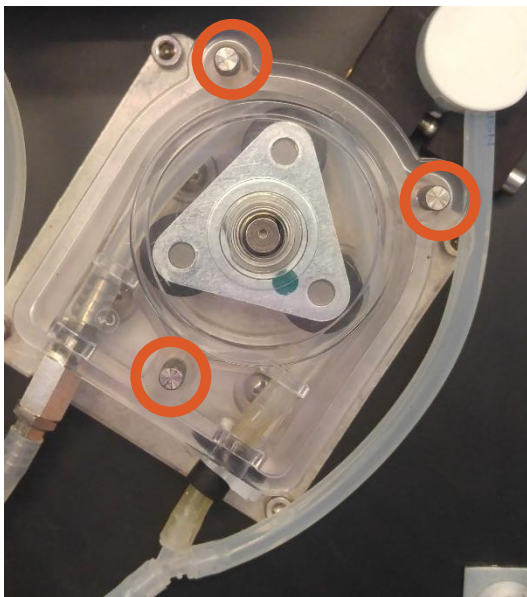

Remove the 3 thumb screws and the plastic cover.

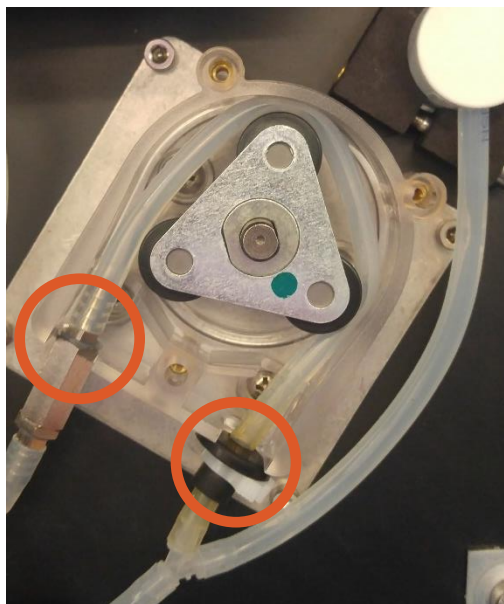

Unhook the tubing at the check valve and the wye.

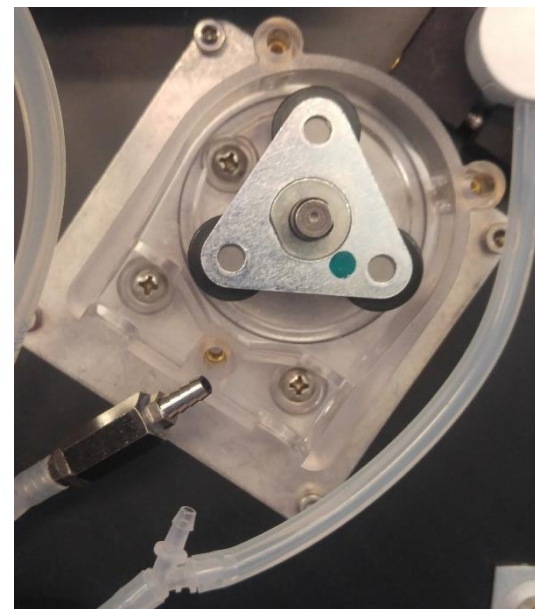

Remove the old tubing, grommet, and clip.

Disassembling the Old Pump Tubing

The retention clip and grommet can be reused. If you plan to use a new retention clip and grommet, skip to the Assembling the New Tubing section below. To remove the retention clip and grommet for reuse:

- Open the retention clip by pressing the middle section towards the grommet until the clip opens.
- Remove the clip.
- Slide the grommet off the tubing.
- Discard the old tubing.

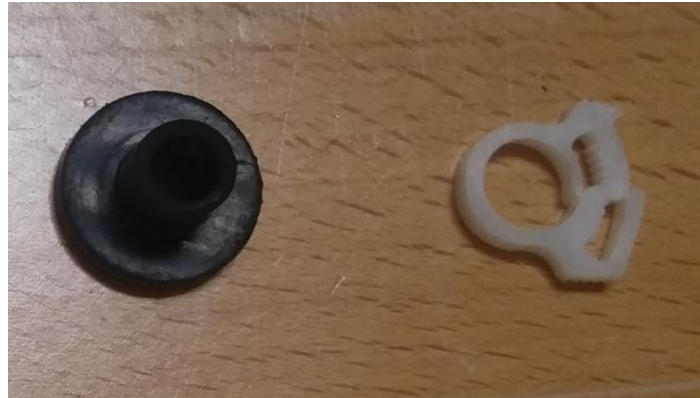

Assembling the New Pump Tubing

- Cut a 27 cm piece to new tubing.
- Slide the rubber grommet onto the tube as shown below.
 - Leave about 1.5 cm of tubing protruding.
 - A drop of water can be used to aid in sliding the grommet on if necessary.
- Firmly install the retention clip.



Installing New Tubing

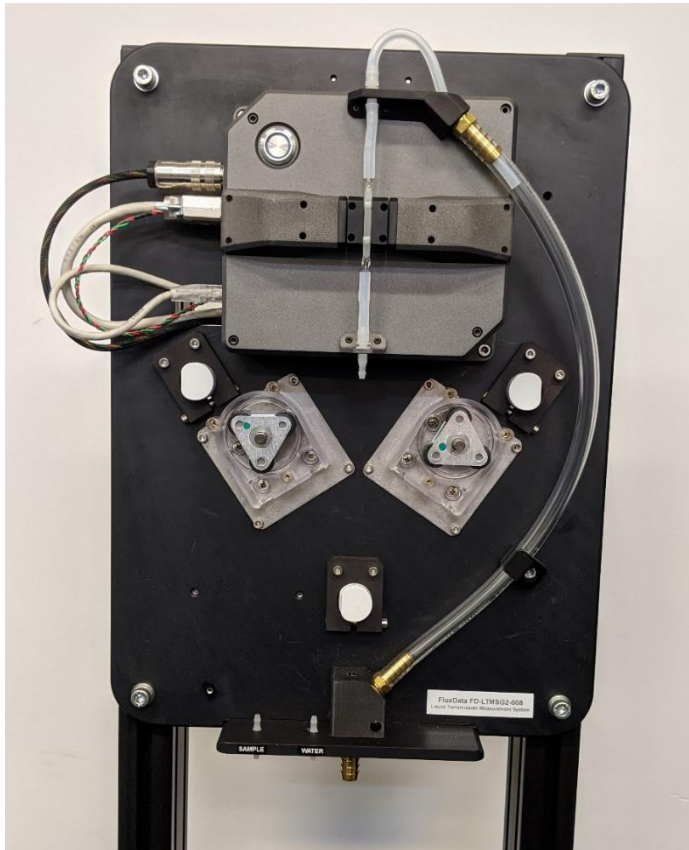

Cut a 15.5 cm piece of tubing and install here.

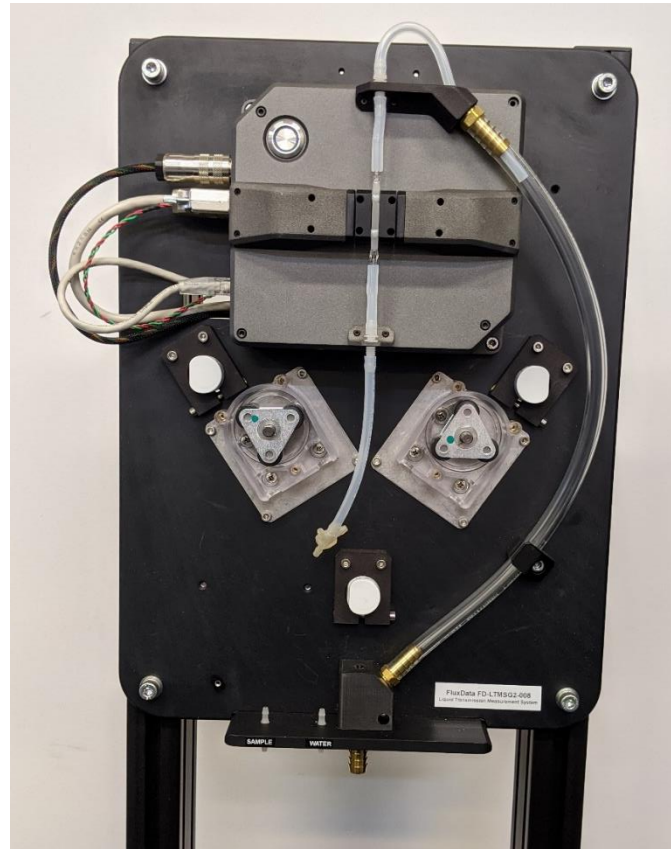

Cut a 13.5 cm piece of tubing and install here. Attach the bottom of the tubing to the 4-way fitting at the bottom as shown.

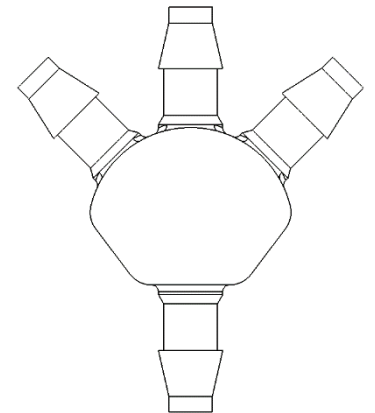

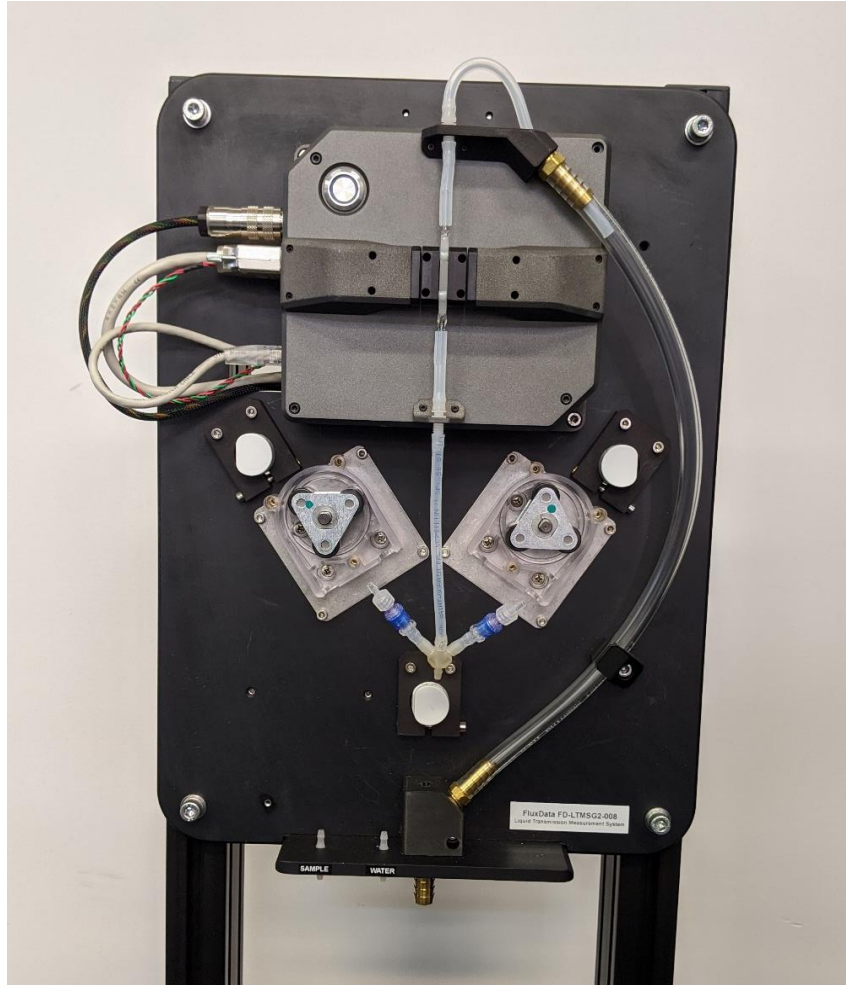

Cut two 2.5 cm pieces of tubing and install below the pumps. Install check valves in the direction shown where the arrow indicates flow direction.

Cut two 18.0 cm pieces of tubing.

Install the rubber grommet and clip on one end of each piece.

Install the other end of each piece onto the check valves installed in the previous step.

Install each piece into the peristaltic pump by rotating the pump (counter-clockwise for the left-hand pump, and clockwise for the right-hand pump) and pressing the tubing into the pump ahead of the rollers.

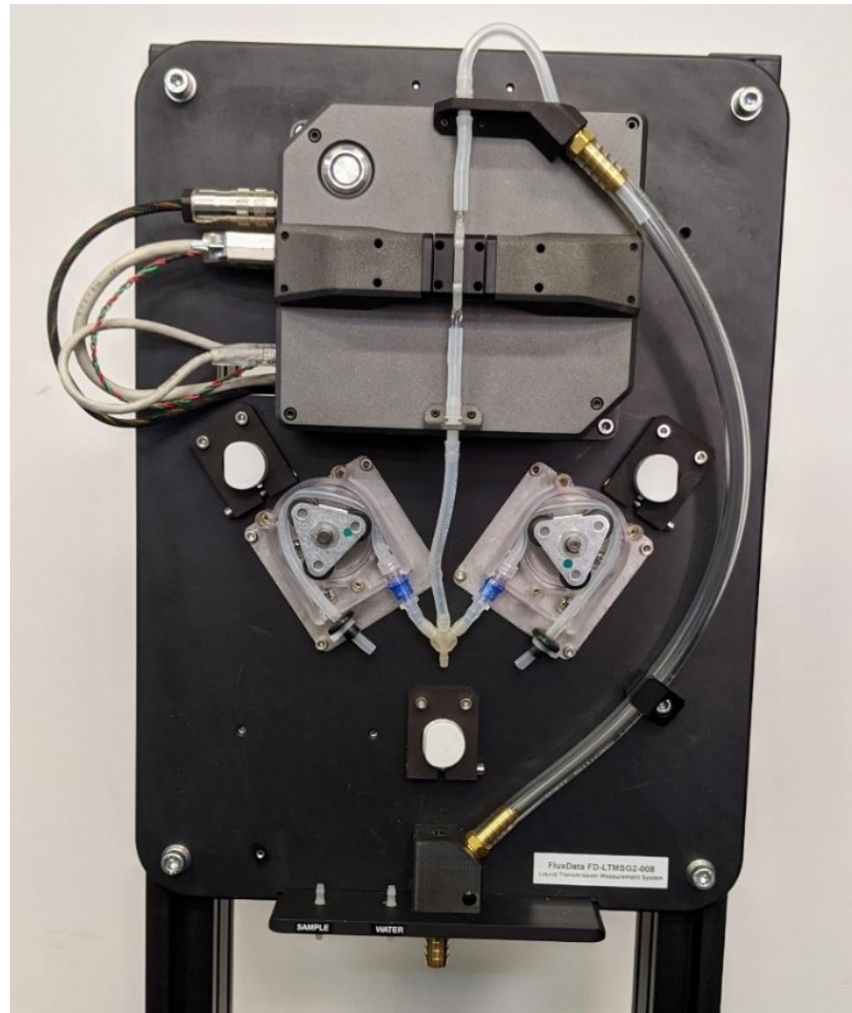



Attach a wye fitting to the grommet end of the pump tubing for both pumps.

Cut two 15.0 cm pieces of tubing and attach to the other side of the wye fitting.

Install the other end of the tubing into the pinch valve.

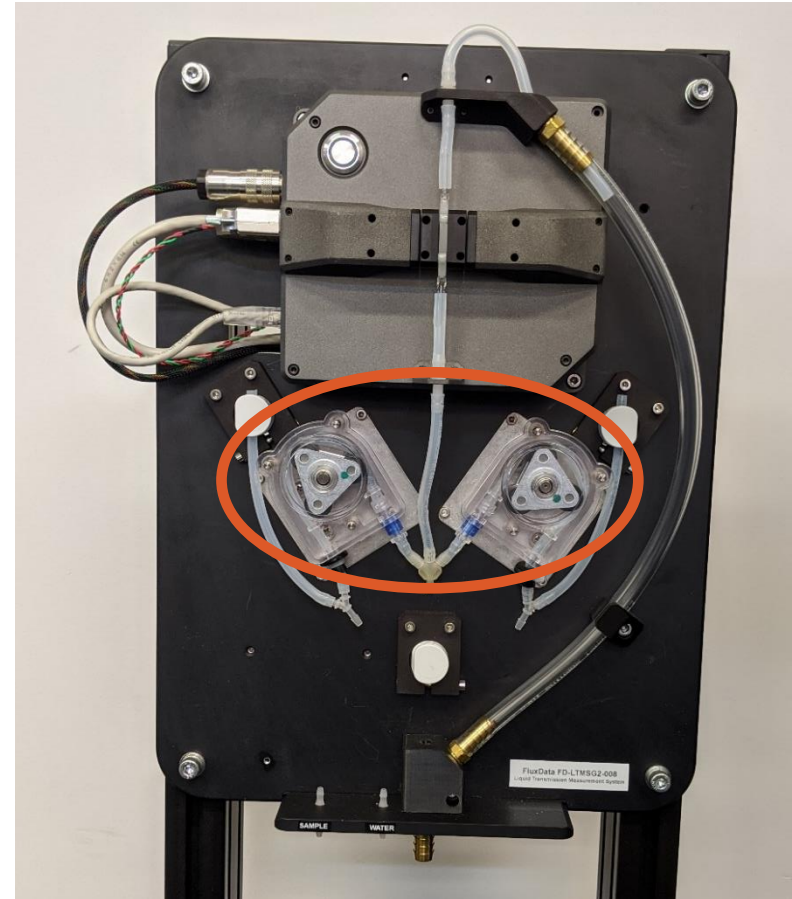

Replace the pump covers with three thumb screws each.

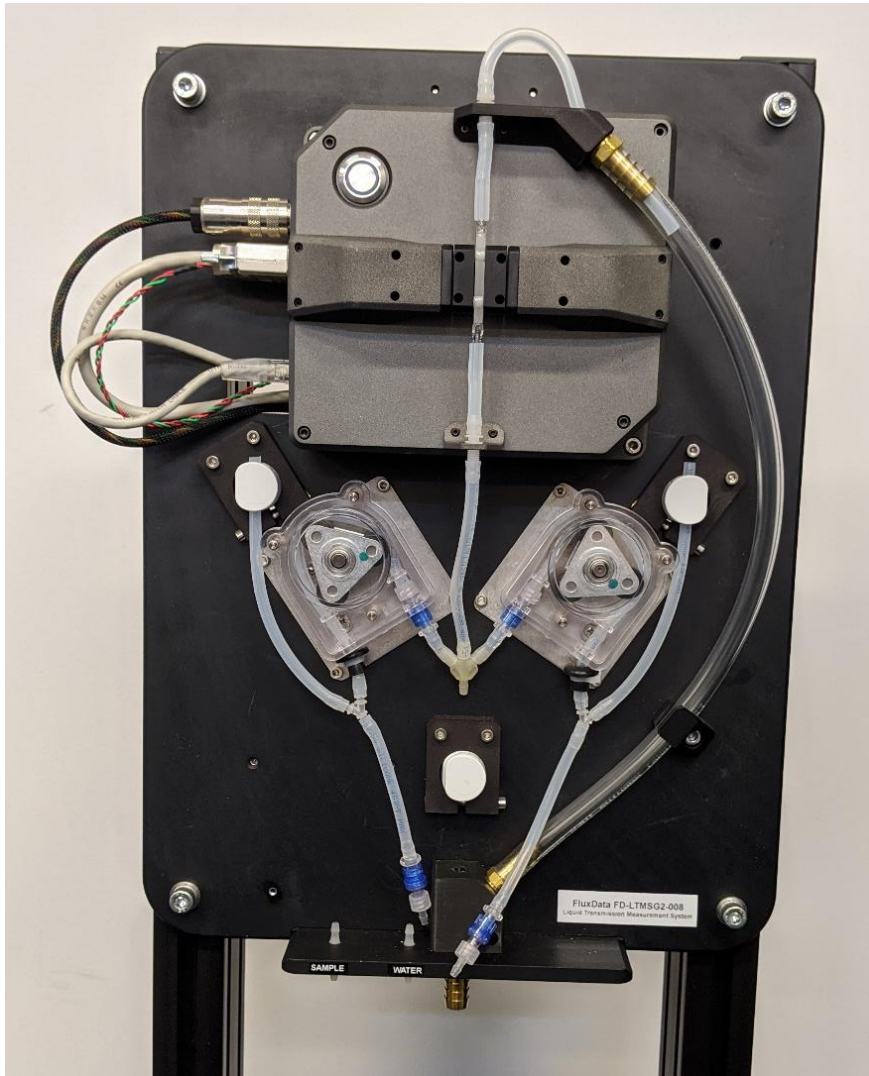

Cut an 8 cm piece of tubing and attach to the wye fitting on the left side.

Attach a check valve in the orientation shown below to the bottom of the tubing.

Cut an 11 cm piece of tubing and attach to the wye fitting on the right side.

Attach a check valve in the orientation shown below to the bottom of the tubing.



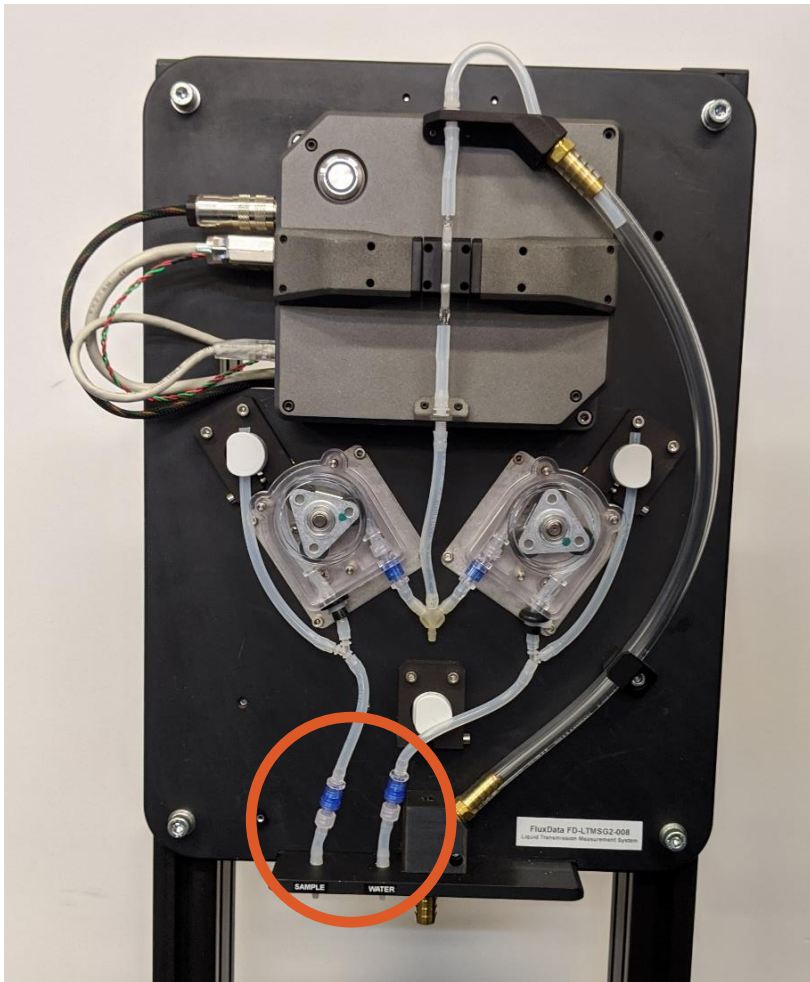

Cut two 3 cm pieces of tubing and attach to the check valves.

Attach the other end of the tubing to the barbs installed on the system plate.

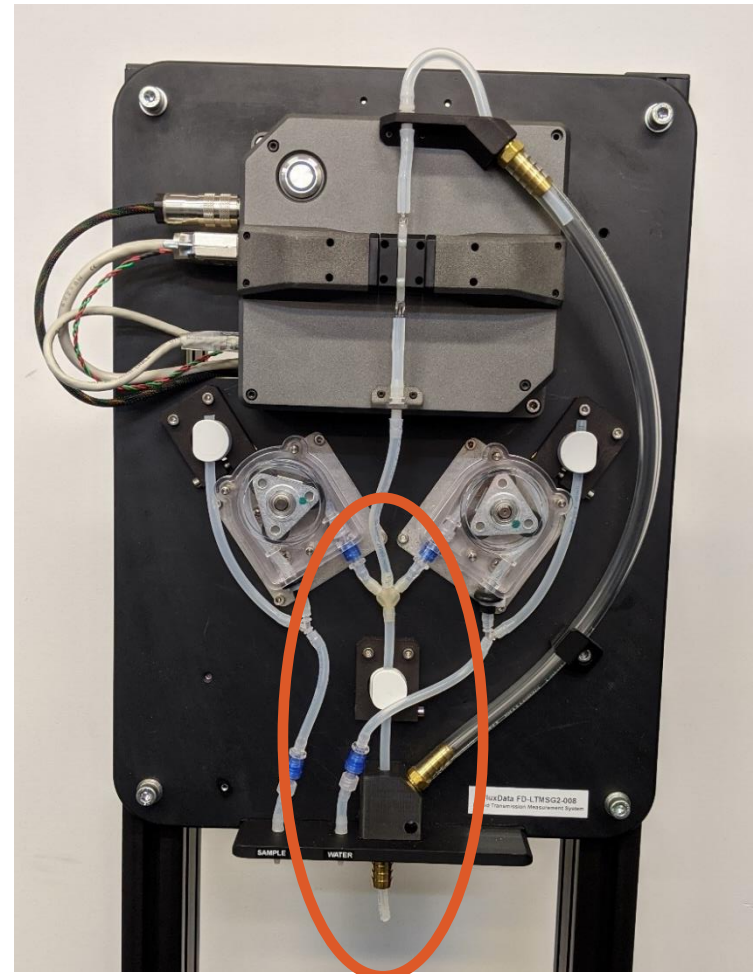

Cut an 18 cm piece of tubing and attach to the bottom of the wye.

Insert the tubing into the drain (some will poke out of the brass fitting).

Insert the tubing into the pinch valve.

Flow-cell Changeover Procedure

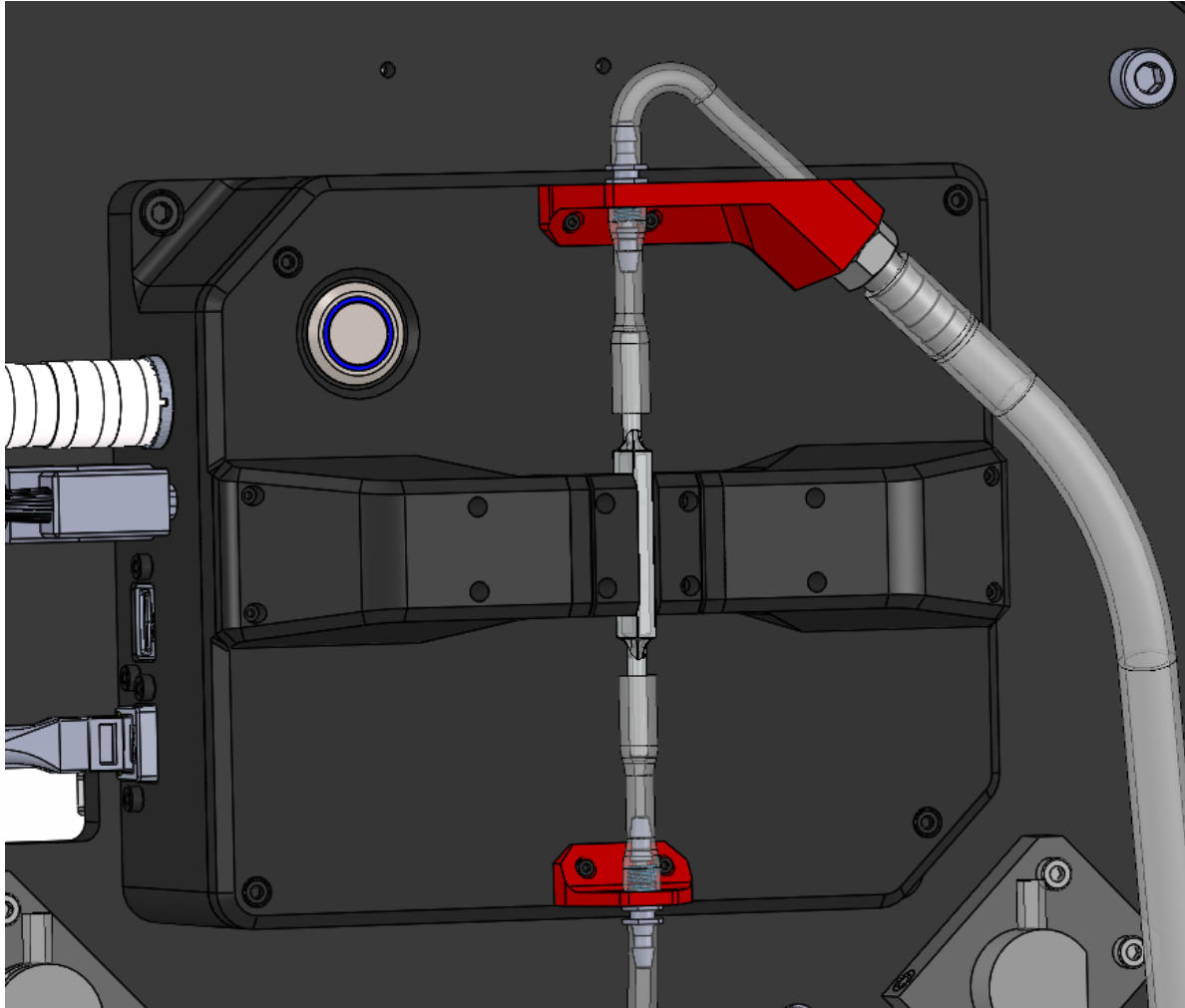

Remove the strain relief brackets held by M2 SHCS, one bracket at a time, and detach the tubing from the glass flow-cell by gently pulling along the long axis of the flow-cell to prevent breaking the glass tube.

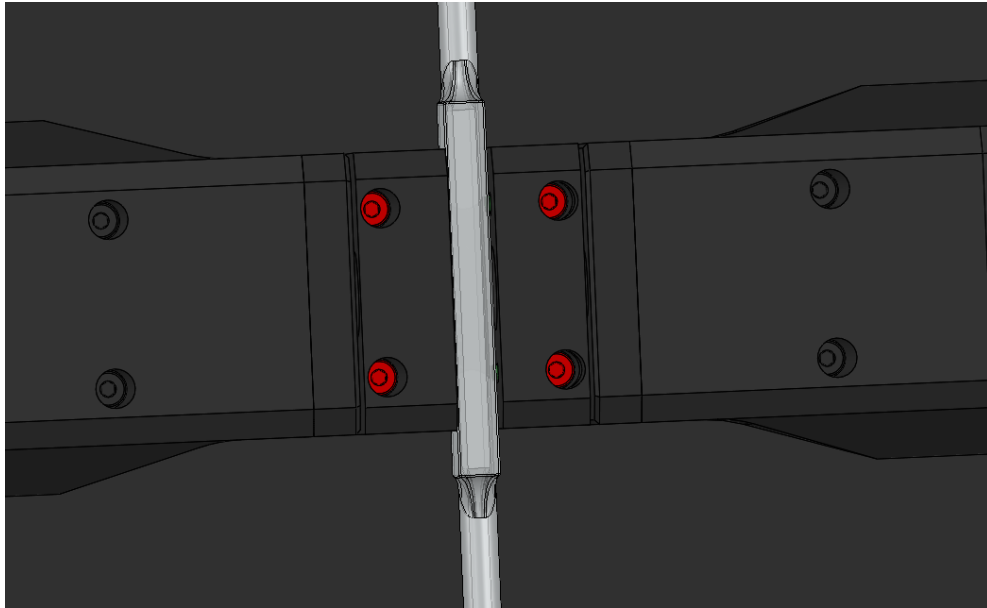

Remove the four M2 SHCS from the flow-cell mounting block. The flow-cell mounting block can now be removed.

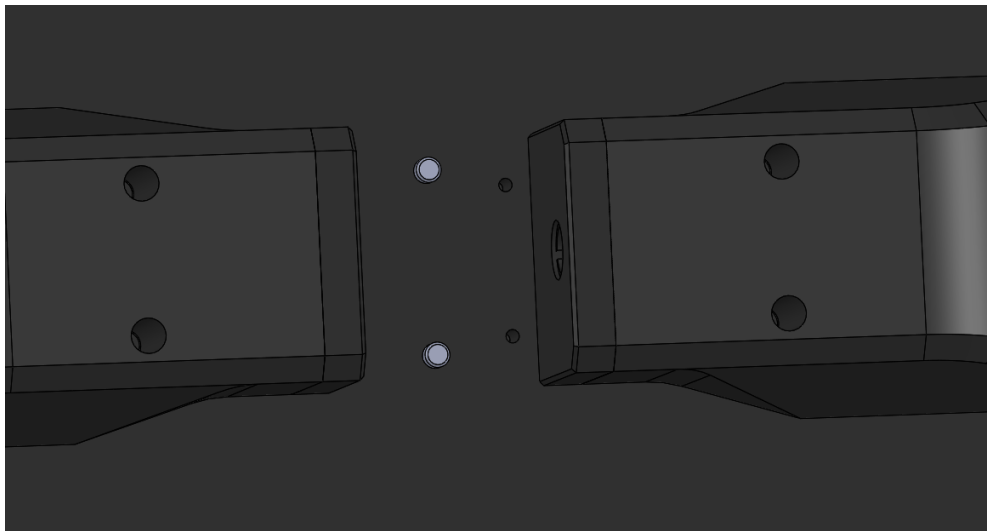

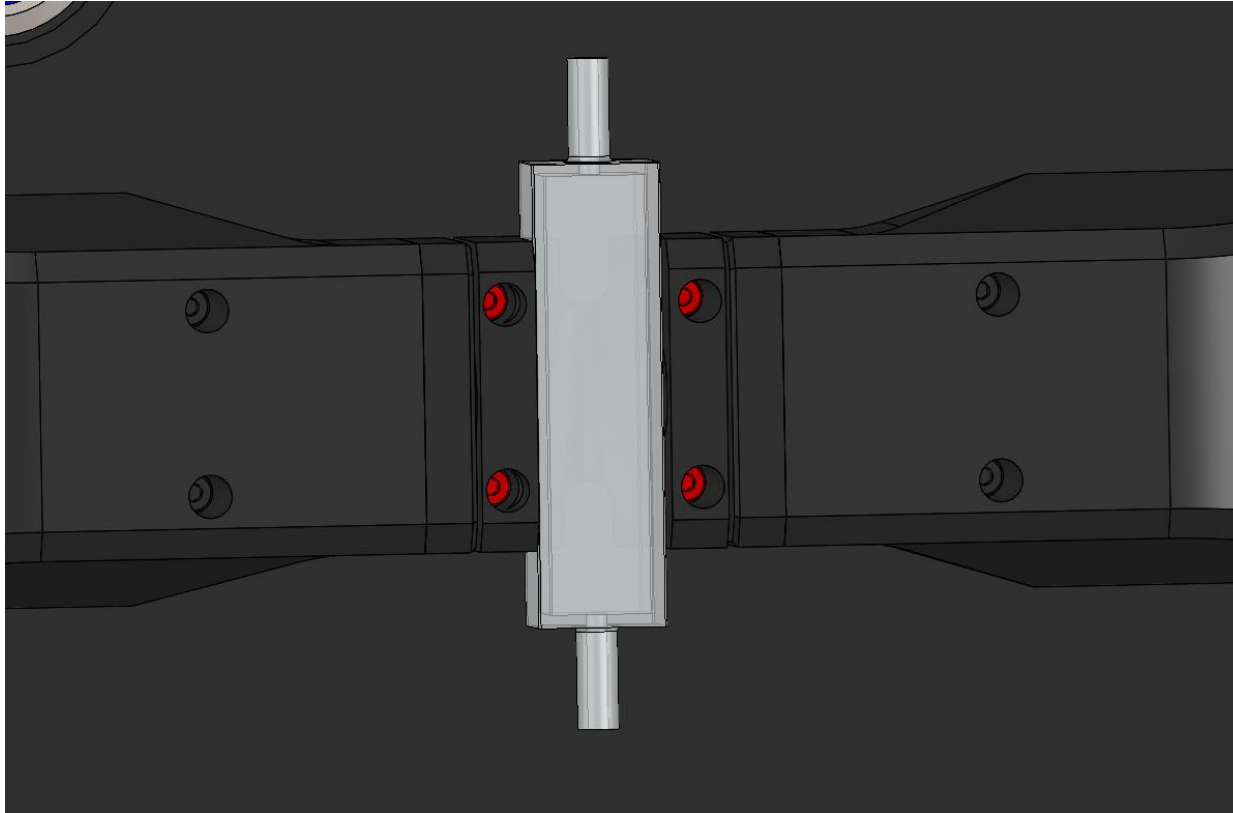

Install the new flow-cell assembly. Note that there are two dowel pins installed on the measurement cover that align to a hole and slot on the underside of flow-cell block.

Verify the mount is flush with the measurement head cover. Then fasten into position using the four M3 SHCS.

Troubleshooting

Sometimes things do not go to plan. If not, do not hesitate to contact us and our Tech Support team will leap into action. Some typical questions are answered here. For more information, consult the FAQs on the Ocean Insight website.

If you are having trouble connecting to the instrument (via ethernet).

Ensure the computer you are using has an IP address of 10.14.15.XX. XX can be any number except for the system serial number.

If your sample is measuring too dark (maximum transmission < 10%).

Change to a shorter path-length flow-cell.

If your sample is measuring too light (minimum transmission > 90%).

Change to a longer path-length flow-cell.

If liquid is draining out of the flow-cell.

Replace the check valves.

If the pumps are moving less fluid than usual.

Replace the tubing.

Specifications

	Sensor Only	Sensor with Integrated Pump
PHYSICAL		
Dimensions (mm):	180 x 160 x 100	980 x 410 x 460
Weight (kg):	4	33
Sample interface:	Flow-cell or cuvette holder; customized hard fixturing also available	
SPECTROSCOPIC		
Wavelength range:	400-700 nm	
Optical resolution (FWHM) ³ :	1.0 nm	
Signal-to-noise ratio at full signal:	~8000:1*	
Cycle time:	40 ms (minimum) to 3-5 seconds	
Output:	Light source-compensated transmission/absorption	
COMPUTER		
Communication protocol/interface	TCP/IP over Ethernet RS-232 RS-485 ModBUS RTU to PLC	

* Using 100 water measurements over 600 s.

Unlock the Unknown

Ocean Insight exists to end guessing. We equip humanity with technology and data to make precisely informed decisions providing transformational clarity for human advancement in health, safety, and the environment.

Questions?

Chat with us at [OceanInsight.com](https://oceaninsight.com).

info@oceaninsight.com • **US** +1 727-733-2447

EUROPE +31 26-3190500 • **ASIA** +86 21-6295-6600